

Wine & Beer Dealcoholization

Winemakers and brewers are careful not to produce wine or beer with too much alcohol as this may pose a variety of challenges. With too much alcohol, the wine or beer may taste “hot” and may not sell at full value or result in additional taxes. Also, if the alcohol by volume (ABV) in the bottle differs from that stated on the label, compliance issues may result.

Additionally, the demand for nonalcoholic beverages is increasing due to newer consumption practices that are reducing alcohol intake for a variety of reasons: healthier lifestyle, drinking and driving regulations, religious reasons, pregnancy or abstinence. As such, more and more nonalcoholic beer and wine beverages are being produced with a maximum ABV of 0.5%.

There are several ways to produce nonalcoholic or alcohol-reduced beer and wine (Figure 1). Two ways to remove alcohol (ethanol) from beverages is to interrupt fermentation, which restricts the formation of ethanol, or by steaming off the ethanol by boiling. However, both these methods may negatively affect the flavor of the beverage. In order to better control the alcohol content and maintain the beverage’s flavor, winemakers and brewers may use membrane processes, including reverse osmosis, nanofiltration or dialysis, for targeted alcohol reduction or dealcoholization.

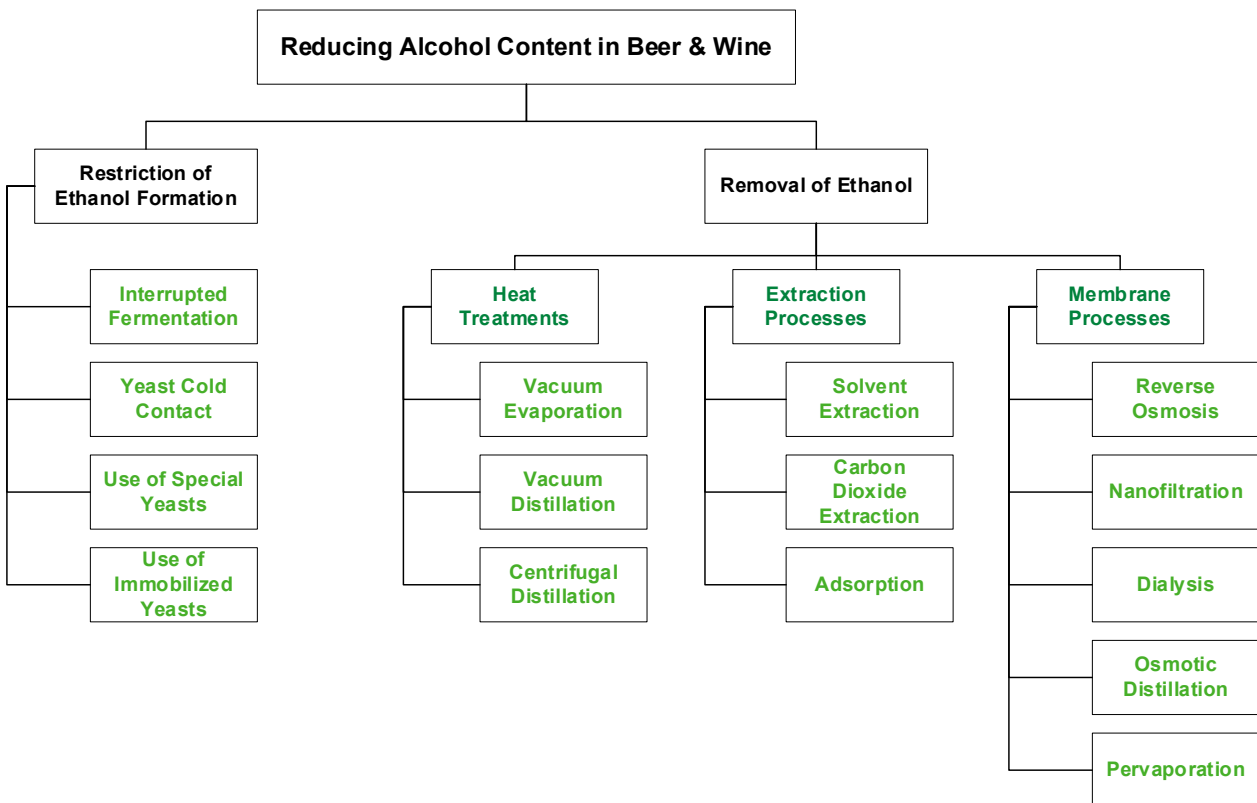

Figure 1. Methods of reducing alcohol content in beer and wine.

REVERSE OSMOSIS & NANOFILTRATION FOR DEALCOHOLIZATION

In order to better control the alcohol content, winemakers and brewers may use reverse osmosis (RO) or nanofiltration (NF) for targeted alcohol reduction or dealcoholization without changing the flavors, tannins and other elements in the wine or beer.

As wine or beer is fed into the RO or NF system, the small, uncharged molecules such as water and ethanol pass through the membrane as permeate while most elements including color, tannins and flavor do not (retentate).

Dealcoholization systems using spiral-wound RO and NF membrane elements are typically operated with diafiltration to help dilute the wine or beer with water to increase the alcohol extraction capacity (Figure 2). As the permeate (mainly water and ethanol) is withdrawn from the feed, deaerated water is added to the retentate at the same flow rate to keep the volume in the system constant. The retentate from the first loop may be sent to a second loop to remove any additional ethanol.

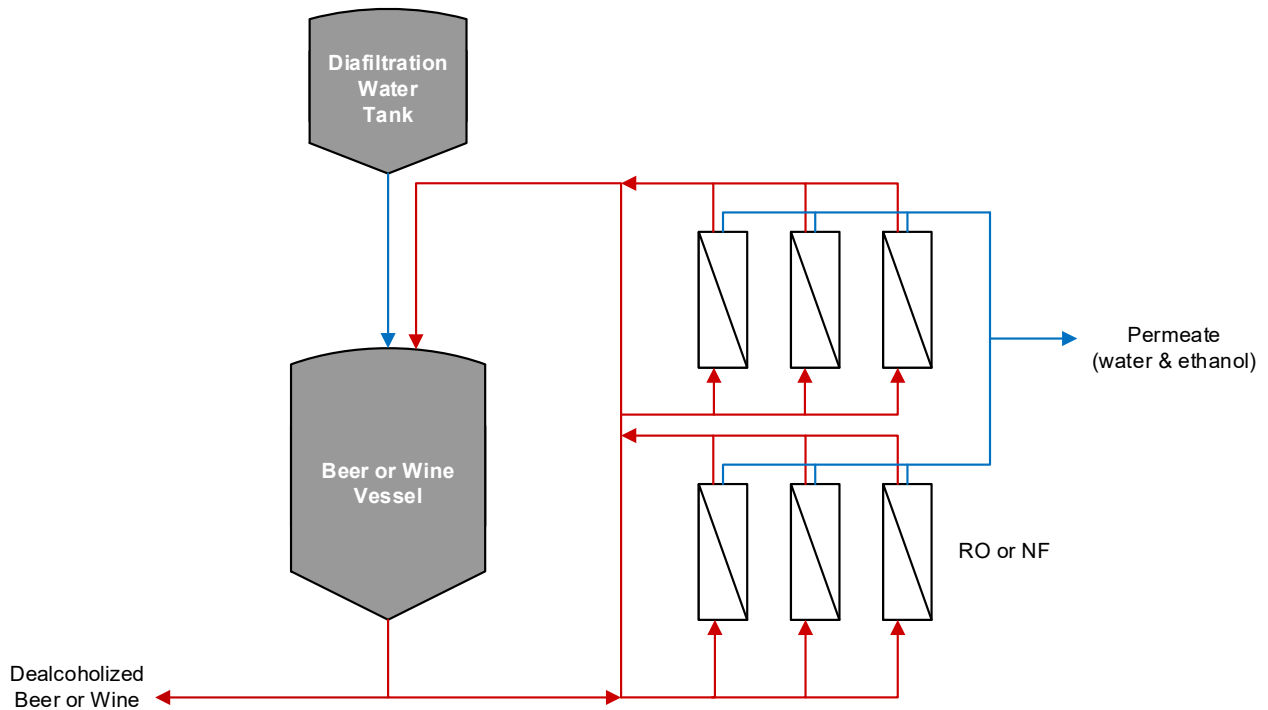

Figure 2. Dealcoholization system using spiral-wound RO or NF elements.

TECHNICAL APPLICATIONS

Alternatively, the RO or NF permeate (the colorless and tasteless water and alcohol mixture) may be distilled to separate the alcohol from the water (Figure 3). The distilled alcohol may be used in the production of other beverages while the water can then be recombined with the RO or NF retentate (the color, flavor and tannins), resulting in a tasteful wine or beer with reduced alcohol.

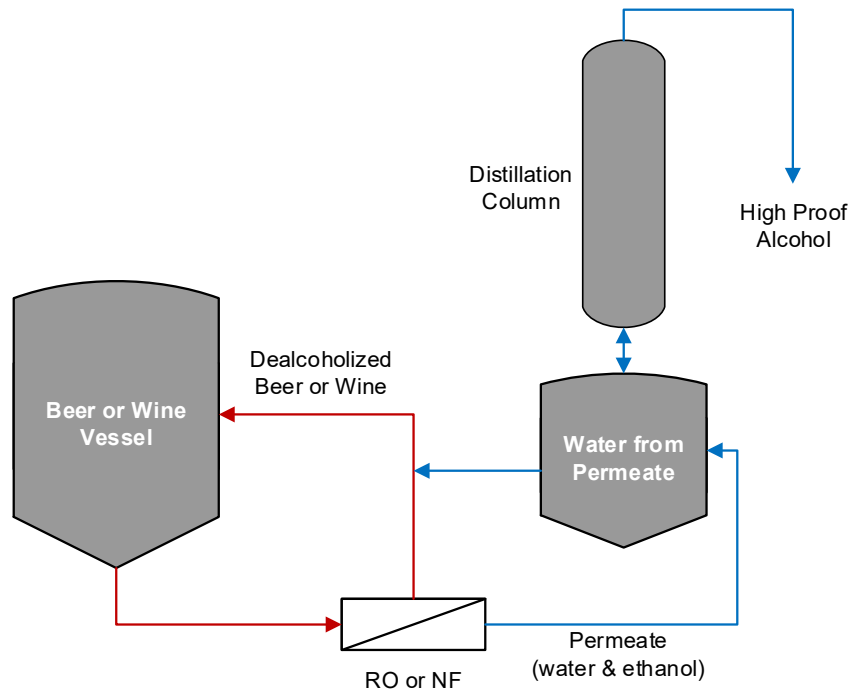

Figure 3. RO or NF system using distillation to remove ethanol from the permeate.

DIALYSIS FOR DEALCOHOLIZATION

Dialysis is another method that uses membranes for ethanol removal. Dialysis is based on the use of capillary membrane modules such as DIADYN CD 4 PS 513 modules. Beer or wine flows counter-currently to the dialysate (e.g. water), as shown in Figure 4. Low molecular weight solutes, such as ethanol, pass through the membrane as a result of the concentration gradient between the two solutions. Ethanol permeates from the beer or wine to the dialysate, trying to reach equilibrium (similar ethanol concentration on either side of the membrane).

The alcohol-rich dialysate is then sent to a stripper column where ethanol is removed by evaporation. The remaining alcohol-free dialysate is reused in the dialysis unit to remove additional ethanol while minimizing the permeation of flavor compounds.

Dialysis, like RO and NF dealcoholization systems, has minimal impact on the flavor of the beer or wine.

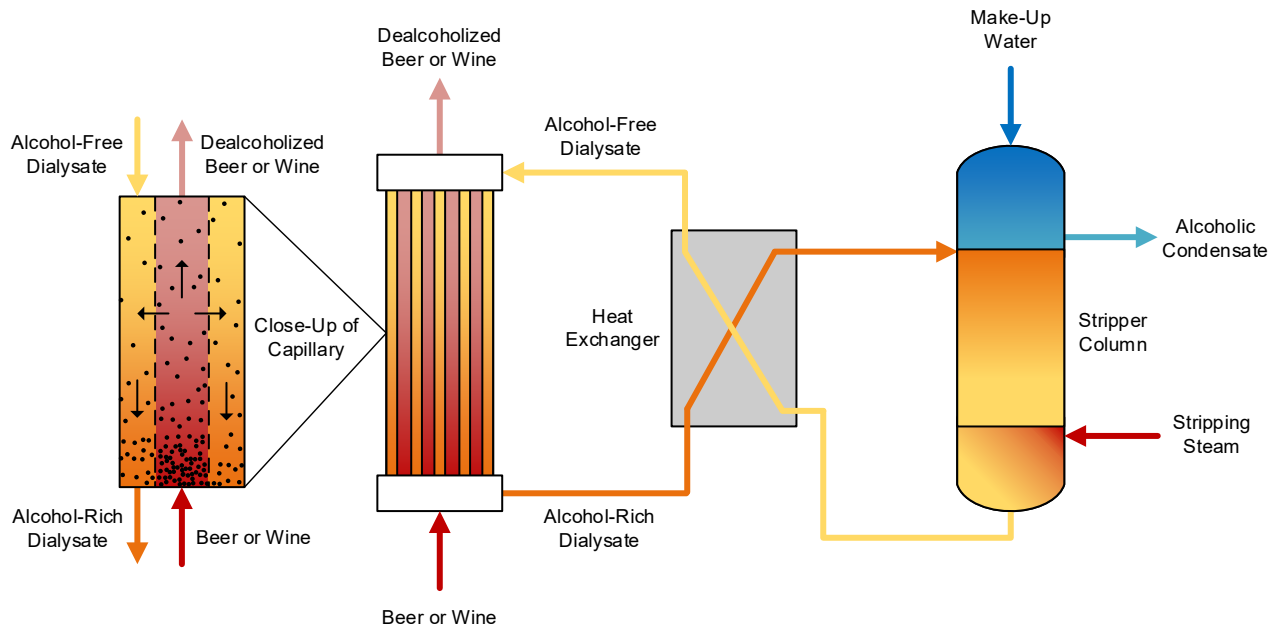

Figure 4. Flow diagram of dealcoholization by dialysis using capillary modules.

For more information or questions on wine or beer dealcoholization, please contact MANN+HUMMEL Water & Fluid Solutions.

Contact

Europe
 Germany: +49 611 962 6001
 Italy: +39 0721 1796201
 info@microdyn-nadir.com

Americas
 USA: +1 805 964 8003
 sales.mnus@microdyn-nadir.com

Asia
 Singapore: +65 6457 7533
 China: +86 10 8413 9860
 waterchina@mann-hummel.com